

How to Make a Folded Face Mask

Materials and Tools:

- Pre-washed cotton fabric. Approx. 10x16" for mask, 6x15" for straps. Fabric can be cut from mixed pieces. Ribbon, cord, elastic, or other pre-made ties can be substituted for fabric straps.
- Sewing machine and thread. You can handsew this mask if you have the time, but you will need to use small, tight stitches.
- Iron and ironing board.
- Paperclip (or pipecleaner or other formable wire)
- Sharp scissors (for cutting fabric).
- Needle for finishing loose threads.

1

Cut out paper pattern templates (pages 4-5). Fold and iron cotton fabric. Place mask template on fabric fold as shown. Cut 2 mask pieces.

2

Place strap template on fabric fold. Cut 4 strap pieces. You may need to refold and iron to make efficient use of the fabric.

3

Place nose template on fabric. Cut 1 nose piece.

4

Make 4 straps as follows:

- a** Fold and iron the strap in half length-wise. This will create a center crease along the length of the strap.
- b** Unfold the strap and then fold and iron both the top and bottom edges in to meet the center crease.
- c** Re-fold and iron on the center crease.
- d** Stitch the folded edges together.

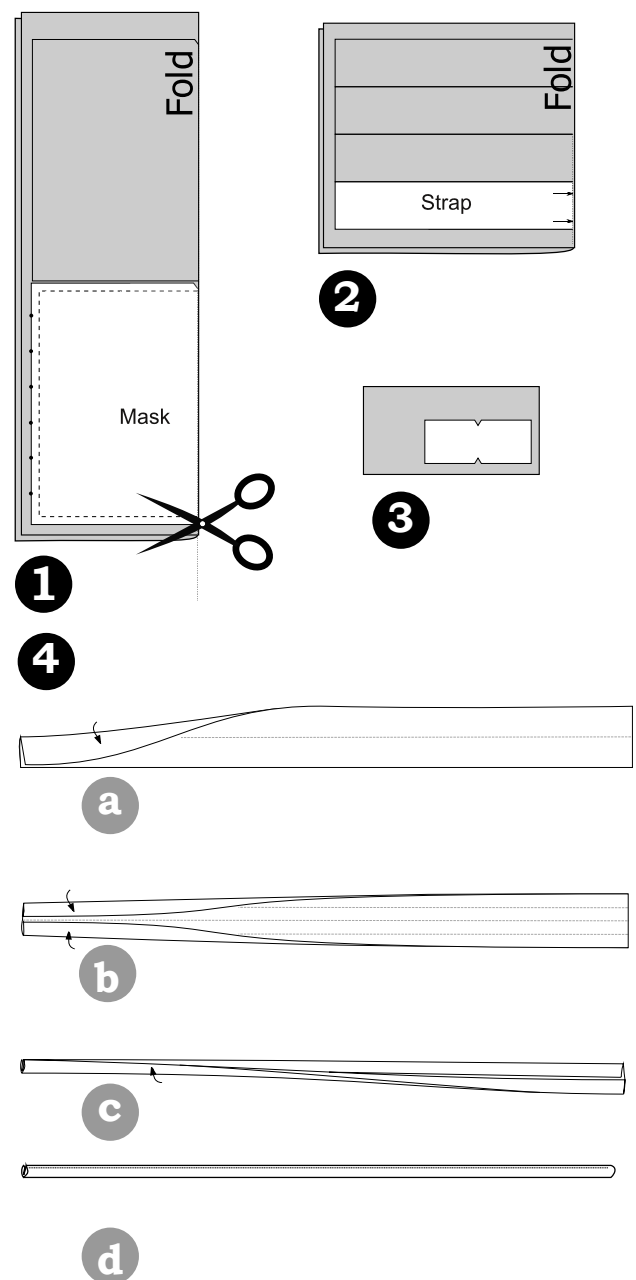

5

Make the nose clip as follows:

- a** Obtain a small wire, about 2 ½" in length. An unfolded paper clip, pipe cleaner, or other shape-holding wire will work. Use needle-nose pliers to curl the ends of the wire in so that they won't poke through the fabric.
- b** Iron nose piece fabric. Fold and iron a ¼" crease along bottom edge.
- c** Fold and iron crease over again (about ¼") to form a tube that is open on both ends.
- d** Stitch one side of the folded tube closed. Insert wire.
- e** Stitch other side of folded tube to secure the wire.
- f** Optional: Zig-zag stitch over wire, being very careful not to stitch directly on the wire, to further secure it.

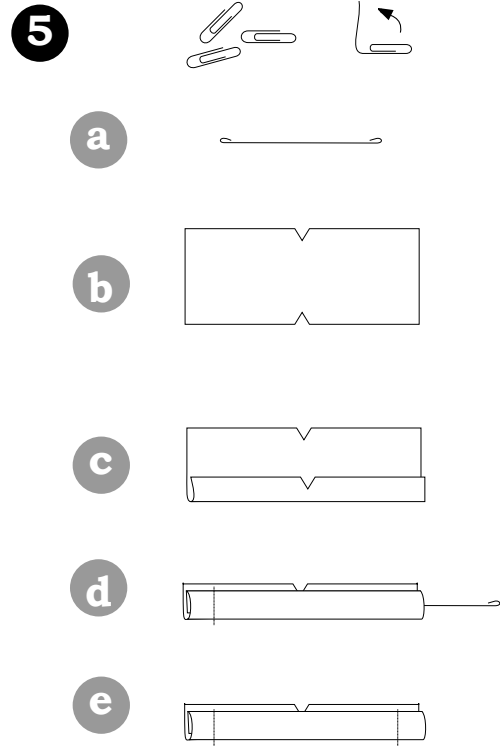

6

Match the mask pieces together with the right-side of fabric facing in. Note the notches at the center of the top edge and make sure they are aligned. Place the nose clip so that the notch is aligned. Pin in place.



7

Place a strap at each corner between the mask pieces. The end of the strap should just poke out ¼" from the edge of the mask. Secure each strap with a pin. To avoid stitching over the opposite ends, the straps should be gathered inside the fabric and come out at the bottom edge of the mask.

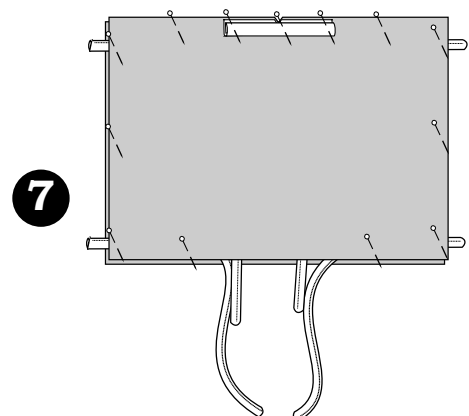

8

Stitch around the edge of the mask, starting on the bottom edge from about 2 inches from the corner, to the corner, around the mask and back to the bottom edge, stopping about 2 inches after. This will leave about 6 ½" open on the bottom edge.

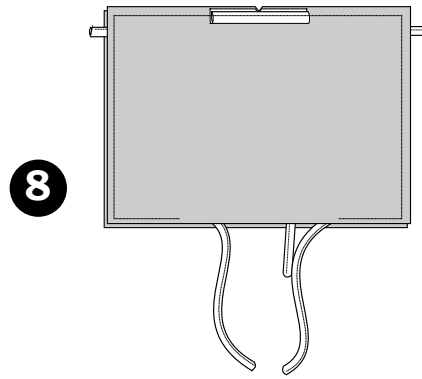

9

Turn the mask inside-out, through the opening on the bottom edge.

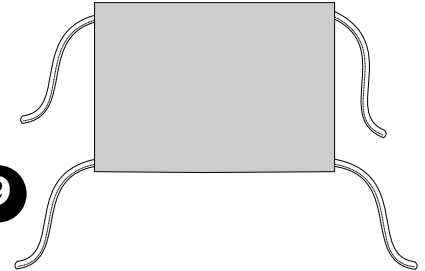
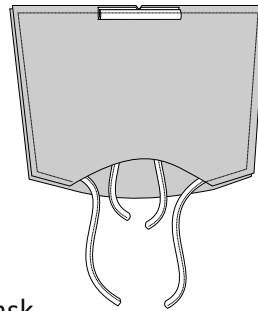

10

Fold and iron 3 creases length-wise along the mask. The creases should all be uniform in direction. The pattern template indicates where fabric can be folded. Secure the creases with pins along the edges.

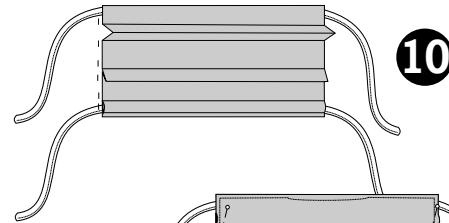

11

Stitch around the top of the mask, about ⅛ to ¼" from the edge. Be careful when stitching the top edge around the wire nose piece. Allow at least ¼" clearance.

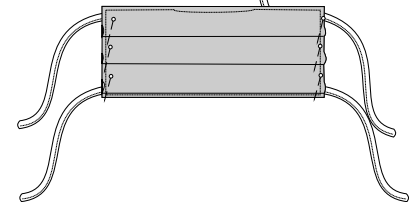

12

Finish any loose ends. Use a needle to bury hanging threads on the inside of the fabric. Clip the ends of the straps at an angle to prevent fraying.

13

Place the mask on your face and bend the wire nose piece over the bridge of your nose. Tie the straps behind your head. Tie the top straps over your ears and tie the bottom straps together to secure the fabric around your chin.

